

## Portable Multifunctional Power Station Manual

# S SERIES

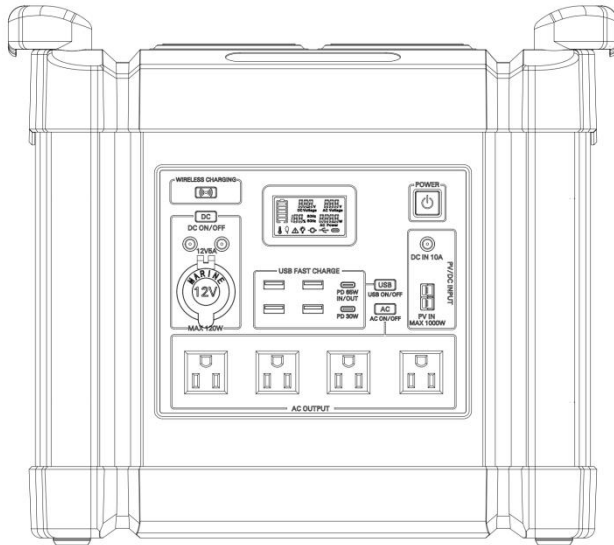

1. Keep S series and the accessories dry and do not expose them to high heat.
2. Never disassemble, puncture, shock, crash, or incinerate the product.
3. Recycle and dispose of S series in accordance with the local regulations.
4. Pay attention to safety when handling the S series.
5. People with disabilities or children should use the product under the protection of the supervisor.

## Glossary

The following terms are used in this document to indicate various levels of potential harm that may be caused by improper operation.

### NOTICE

The instructions, if not properly followed, may result in property damage and minor physical damage.

### CAUTION

The instructions, if not properly followed, may result in property damage and serious physical damage.

### WARNING

The instructions, if not properly followed, may result in property damage, major accident and serious injury.

### WARNING

Read the ENTIRE user manual to be familiar with the features of this product before operating. Failure to operate the product correctly may result in damage to the product or personal property and cause serious injury. we will not assume any legal responsibility. DO NOT use the product with incompatible components or alter the product in any way without following the instructions provided by US. Otherwise, you cannot get after-sales service from US under warranty condition. These Safety Guidelines include instructions for safety, operation and maintenance. It is important to read and follow all the instructions and warnings in the user manual before assembly, setup or use the product.

## Product Safety Guidelines

### WARNING

Improper use may result in fire, property damage or personal injury. Make sure to use the product according to the following safety rules and guidelines

## Product Use

1. DO NOT expose the product to any liquids. Do not immerse the product in water. DO NOT leave the batteries out in the rain or near a source of moisture. Moisture in the device could cause short circuits, component failure, fires or even an explosion.
2. Must be our official accessories, if necessary, please go to the official website to buy. For the use of other brands of accessories caused by property damage, we do not assume any responsibility.
3. Never install or remove other modules from the S series when it is turned on. Do Not plug or unplug other modules when the power of the product is turned on, otherwise the power interface may be damaged.
4. The product should be used in temperatures between  $-20^{\circ}\text{C}$  and  $60^{\circ}\text{C}$ . The use of product in environments above  $60^{\circ}\text{C}$  may cause fire or explosion. Using product below  $-20^{\circ}\text{C}$  will severely affect the performance of the product. Allow the product to return to a normal operating temperature before use it.
5. DO NOT use the batteries in strong electrostatic or electromagnetic environments. Otherwise, the battery control board may malfunction and cause a serious accident during use.
6. Never disassemble or pierce the product in any way. Otherwise, it may leak, catch on fire, or explode.
7. DO NOT use the product if it was involved in a crash or a heavy bump.
8. If the product falls into the water during use, take the product out immediately and put it in a safe and open area. Keep a safe distance from it until it is completely dry. Never use it again and dispose it properly as described in the Battery Disposal section below. If the product catches fire, it is recommended to use fire extinguishing equipment in the following order:

water or water mist, sand, fire blanket, dry powder, carbon dioxide fire extinguisher.

9. DO NOT put the machine in a microwave oven or in a pressurized container.

10. Do Not allow pins, wires or other metal pieces to insert to the device case, outlets or controls. Metal pieces may short circuit the product.

11. Avoid collision. DO NOT place heavy objects on the machine.

12. If there is dirt on any plug or outlet surface, use a dry cloth to clean it. Otherwise, it will cause abrasion and result in energy loss or inability to charge.

### **Product Charging**

1. Always use our approved charging cables. We do not respond to any damage caused by using non-approved charging cable.

2. When charging, please place the product on the ground with no flammable or combustible materials around. To prevent accidents, never leave the machine unattended during charging.

3. DO NOT charge a product immediately after a long heavy load, because the product's temperature may be too high. DO NOT charge a product until it cools down to room temperature. The product may be unable to charge out of the temperature range 0°C to 45°C, The ideal charging temperature range is 15°C to 30°C

### **Product Storage and Transportation**

1. Keep the product out of the reach of children. If any children accidentally swallow parts, please go to a doctor immediately.

2. If a low-battery warning appears, charge the battery before store it. Otherwise, long-term storage may cause damage to the battery in the product. Batteries in the product will enter hibernation mode if it is depleted and stored for a long time. Recharge the product can bring the battery out of hibernation.

3. DO NOT place the product near a heat source, such as a car in direct sunlight, a fire source, or a heating stove.

4. Store the product in dry environments. Please keep the machine away from water.

5. Make sure no small metal objects can fall on or around the product while in storage.

6. Never ship a product with a battery power level higher than 60%.

### **Product Battery Disposal:**

1. Dispose the product in specific recycling boxes only after a complete discharge. Batteries are hazardous chemicals. Please strictly follow your local regulations regarding the battery disposal and recycle.

2. Dispose of the product immediately if it cannot be powered on after over-discharging.

### **Product Maintenance:**

1. Never store the product in environments below -20°C or above 60°C .

2. If the product is not used for a long time, the battery life may be reduced.

3. Fully charge and discharge the battery at least once every 3 months to keep the battery healthy.

## **S series Use Care and Safety Guide**

It is forbidden to carry lithium batteries and equipment with a capacity greater than 160Wh on airplane due to the regulation; Do Not bring this product on flights.

### **CONGRATULATIONS**

You now own the best quality Portable Battery Generator in the world. This brief pamphlet is meant to help you.

Please take some time to read it before using the product. Read it through to fully understand how to use the

Lithium Generator!

## NOTICE

To turn S series on or off, you need to PRESS and HOLD the ON/OFF system Power Button. To turn on the AC power outlet, you need to PRESS and HOLD the AC Button after turning on S series. Please follow this introduction step-by-step to be familiar with each of S series's ports, buttons, display screens and more. Get the new machine, please first charge up to 100% before use it.

## FCC Statement

This device complies with Part 15 of the FCC Rules. Operation is subject to the following two conditions:

1. This device may not cause harmful interference, and
2. This device must accept any interference received, including interference that may cause undesired operation.

## WARNING

Changes or modifications not expressly approved by the party responsible for compliance could void the user's authority to operate the equipment.

## FCC Radiation Exposure Statement

This equipment complies with FCC radiation exposure limits set forth for an uncontrolled environment. This equipment should be installed and operated with minimum distance 20cm between the radiator & your body.

## PRODUCT FEATURES

Multi-function portable generator is made not only for emergencies backup power at home, is very useful for camping, or wherever you need power when you are on the go. With high power/energy, you can keep your electrical devices, appliances, lights and more going for longer. Variety of quick charging modes and a rich product range.

## The products are divided into the following series

### Standard configuration

1. Built-in MPPT controller, Allows the use of 28-50 volt solar panels to charge up 700w to 1100 watts. Solar panels are sold separately.
2. Super quick charge PD bothway charge 65W and output 65W, QC 3.0 USB output, Output of cigarette lighter, DC output and wireless charging.
3. DC Adapter charge 29.4V5A~10A optional, this ports can charge by CAR

### Optional features

1. **S series** External AC to DC charger
2. **SA series** adds built-in AC charging on the basis of S series
3. **SAL series** adds built-in LED lamp post on the basis of S series
4. **SALM series** adds radio, bluetooth playback and man-machine dialogue on the basis of SAL series
5. **SAA series** Support WiFi or GPS connection and APP remote control

**According to your use needs, buy the corresponding product series**

# CONTENTS

S series User Guide.....	1.2.3.4
Page retrieval.....	5
S series product introduction.....	6
Function declaration.....	7
User Interface Introduction.....	8
Solar Panel Connection.....	9
Charge.....	1 1
Technical Specifications.....	12/13
FAQs .....	14
What' s in the Box.....	14

# S series product introduction

1. DC charge ports
2. PV charge Ports
3. ON/OFF Button of Power
4. LCD display
5. ON/OFF Button of USB and Type-c
6. QC3.0 USB and Type-c output ports
7. ON/OFF Button of AC output
8. AC output ports
9. ON/OFF Button of DC Output
10. DC Output Ports
11. Output hole of cigarette lighter
12. ON/OFF Button of Wireless charging
13. Wireless charging placement area
14. Product model or brand
15. Detailed product specifications
16. Heat sink window

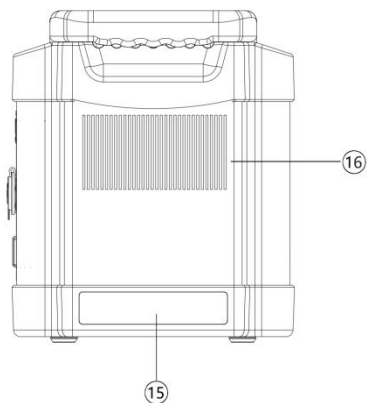
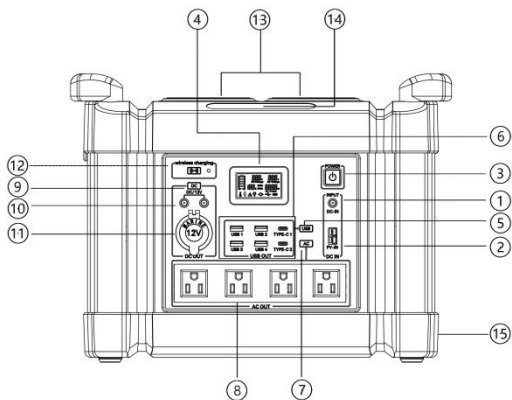

# Function declaration

## 1. DC charge ports

A. S series has a limit input of 294W, can use 29.4V10A DC charger

B. which supports 12V/24V car charge up to 8A (remember to start the engine, otherwise, the car battery may be drained).

## 2 . PV charge Ports (Max 1000w 36V)

Support a maximum of 4pcs 36v250w solar panels to be connected in parallel

Or 10pcs 18v100w solar panel , frist 2 pieces in series, then 5 groups of parallel access to the product(Max 1000w 36V)

## 3 . ON/OFF Button of Power

If you need to use this product, you must turn on the main switch of the power supply before starting other switches. When not in use, please turn off the sub-switch and the main power switch in time to save energy

## 4 . LCD display

The LCD screen will display various voltage, power, quantity, use status, charging status and fault indication, Before using this product, please read the manual and function introduction carefully.

## 5 . ON/OFF Button of USB and Type-C

When you need to use the quick charge function, please turn on the power master switch, and then turn this switch on. When not in use, please turn it off in time to save energy

## 6 . QC3.0 USB and bothway PD charge and output (Type-c fast charge and output ports)

2 Pcs QC 3.0 (5V/3A, 9V/2A, 12V/1.5A) output ; 2 pcs 5V2.4A output

PD 65W In/Out (5V/3A, 9V/3A, 12V/3A, 15V/3A, 20V/3.25A)

## 7 . ON/OFF Button of AC output

When you need to use AC output, turn on the power master switch and then turn this switch on. When not in use, please turn it off in time to save energy

## 8 . AC output ports

The connected AC load should be less than the allowable load power of the product

## 9 . ON/OFF Button of DC Output

When the power master switch is on, then turn on this switch and you can use the DC output jack

## 10 . DC Output Ports

Max 12v8A , 5.5\*2.1mm DC port

## 11 . Output hole of cigarette lighter

Max 12V10A

## 12 . ON/OFF Button of Wireless charging

When you need to use Wireless charging, turn on the power master switch and then turn this switch on. When not in use, please turn it off in time to save energy

## 13 . Wireless charging placement area

If your phone has wireless charging capability, this will provide 2 \* 10 watts of wireless charging power

## 14 . Product model or brand

Put on your model and your brand , if you order us .

## 15 . Detailed product specifications

The main configuration and parameter information for the product is shown here

## 16. Heat sink window

If the high power output for a long time, please do not block the vent, conducive to the release of heat in the machine

# User Interface Introduction

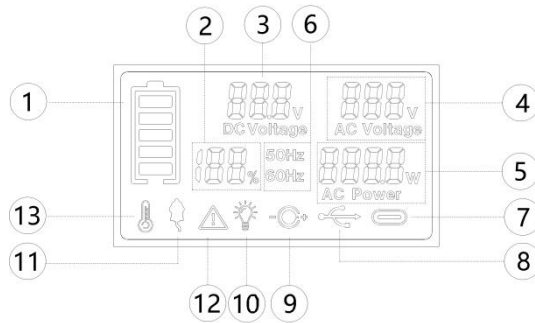

## 1, Battery status display

A , remaining battery is shown at 20%,40%, 65%, 80%,100%

B , the battery status bar will increase when charging, discharge work, the battery status bar will slowly reduce

C , low voltage alarm, the battery frame line will flash,Please charge it in time

## 2, Percentage of battery capacity

current remaining capacity can estimate the time the load can work

## 3, DC voltage (battery voltage )

Display the voltage of the battery when it is not charged;When accessing external power to charge the product, the voltage displayed is slightly higher than the battery voltage.

## 4, AC voltage

Displays the current output AC voltage. During use, please note that the load must be the same AC voltage for normal use.

## 5, AC output power

Total power of the current load

## 6, grid frequency

100-120V60HZ ; 220-240V50HZ

## 7, type-c

This symbol is shown when the product is charged with a fast charge or discharged with a fast charge

## 8, QC 3.0

symbol is displayed when USB is used

## 9, DC output

Displays this symbol when using a 12 volt DC load

## 10, LED lights

This symbol is displayed when the built-in LED lamp is working

## 11, Output of cigarette lighter

This symbol is displayed when output with a cigarette lighter

## 12, warning

Normal not displayed, When the load is too large, the current output exceeds the limit, display this symbol, please reduce the load power as soon as possible.

## 13, Temperature display

Normal display, too high temperature will flash, please stop working, wait temperature to drop before us



# Solar Panel Connection

## How to recharge the S series using solar panels?

If you need to know more about the connection of solar panel, please refer to the Solar Panel User Guide. Here we focus on demonstrate how one to four solar panel in parallel. The S series can support a 30-50V DC input. When the input exceeds 50V, the S series's overvoltage protection will be triggered. Over voltage may damage the product. Users should follow these instructions. SR do not provide free repair services for any product damage caused by connecting many solar panels to the product or incorrect connection, even during the warranty period.

### 1. We recommend this type of fittings and connection as a priority

Anderson 4 in 1 cable accessories, can be up to 4 PCS 36V100-250W solar panels connected to the product in parallel for charging, allowing the maximum access of 36 volt 1000W photovoltaic panels. Suitable for outdoor activities and RV trips

However, SR do not provide free repair services for any damage to the product caused by the quality issue or improper operation of the third-party solar panels, even in the warranty period.

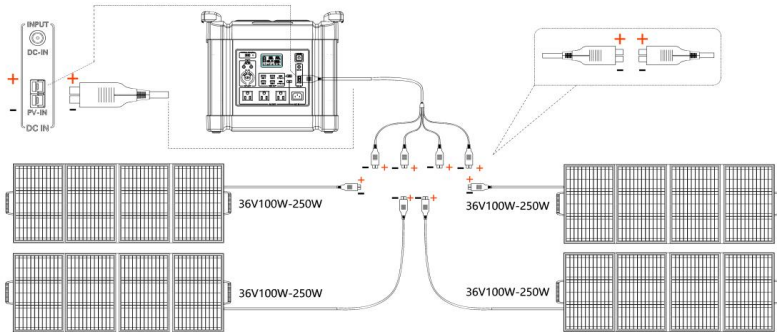

4 PCS 36V solar panels are used in parallel (Max 36V1000W)

### 2. After the series is 36 volts, the maximum cannot exceed 1000 watts

If you have two or four 18 volt solar panel output connectors of MC4, please refer to the following connection.

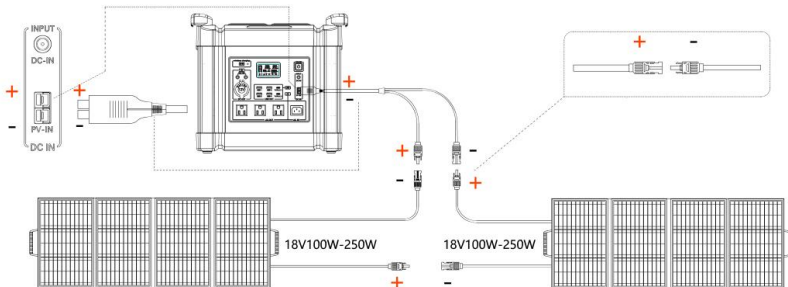

2 pcs 18 volt solar panels connected in series 36 volts

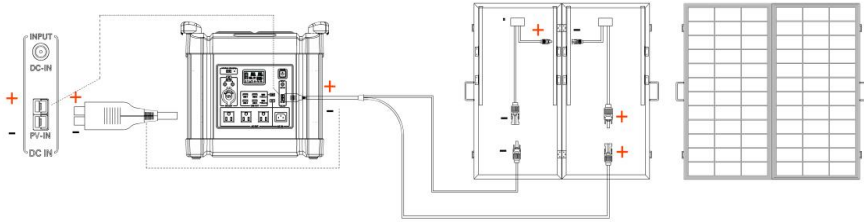

2 pcs 18 volt solar panels connected in series 36 volts

### 3 . 36V solar panels can be allowed in parallel, up to a maximum of 1000 watts

If you have two or four 36 volt solar panel output connectors of MC4, please refer to the following connection.

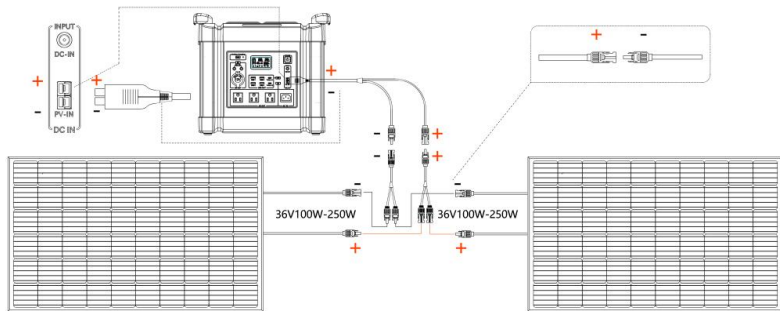

2 PCS 36V solar panels are used in parallel

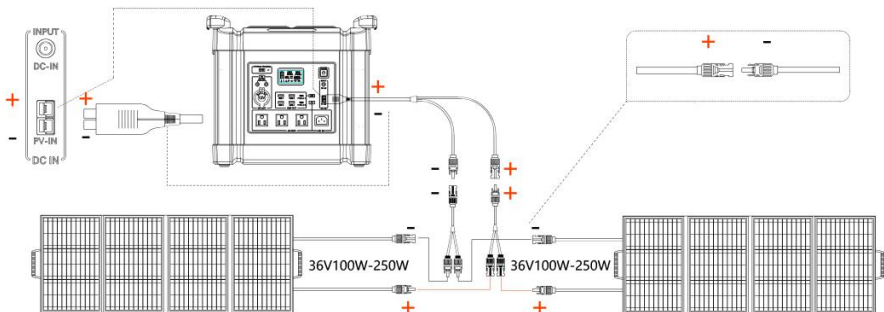

2 PCS 36V solar panels are used in parallel

## 4 . Recharge at home using the included charger

The charger presented randomly is a special charger ( 29.4V4.5A-29.4V10A ), this product does not accept any other charger whose parameters do not match for charging. Please read carefully and follow the rules.

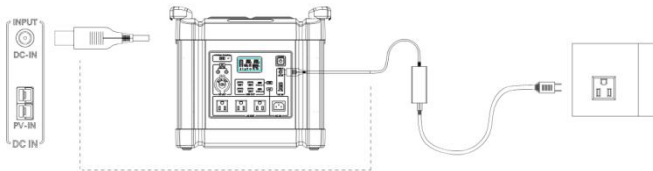

This product can be charged with a portable quick charger. Max 65W

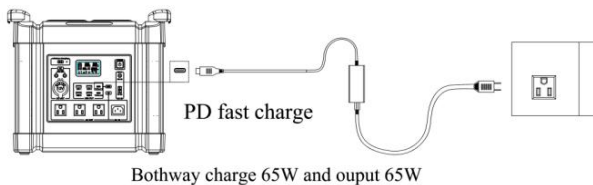

## 5 . Use the car to charge this product

Use the car to charge the product only under very special circumstances. Please note : that it is best to charge the product when the car engine is working. When the car engine is not working, the use of the car to charge this product, a long time will lead to car battery loss.

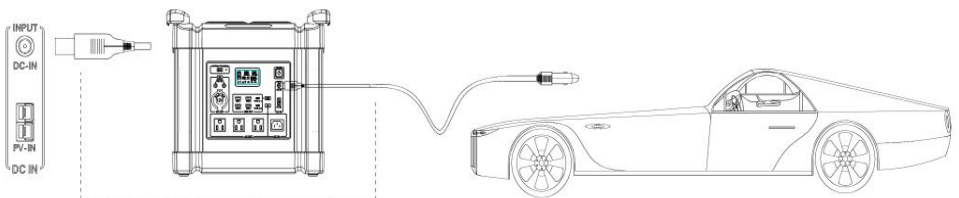

# Choose the appropriate load according to the product model

Note: If the load power used is too large, it will cause the machine to heat too fast, and start protection shutdown. At this time should reduce the load to use. If you stubbornly use high power load, resulting in damage to the product, will not be within the scope of warranty.

## Home Use

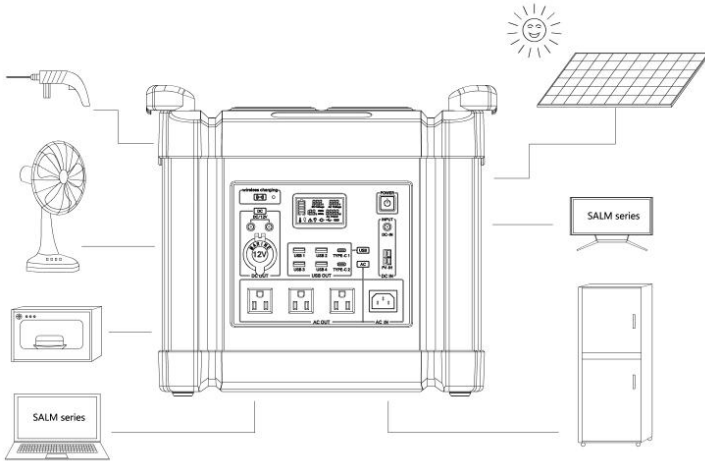

## Outdoor Use

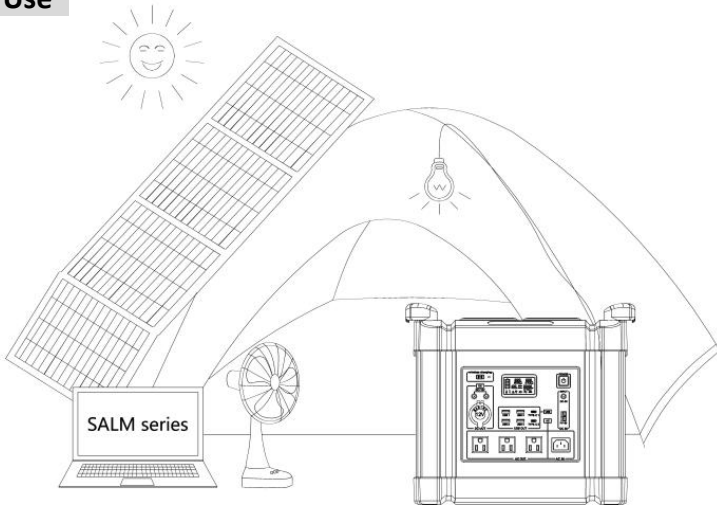

# Technical Specifications

MODEL	S1000	S1500	S2000	S2600	S3100	S4000	S5200
Inverter output	1000W	1500W	2000W	2000W	2000W	2000W	2000W
Peak power	2000W	3000W	4000W	4000W	4000W	4000W	4000W
AC output	220V±10% 50HZ 110V±10% 60HZ						
Waveform	Pure sine wave						
Frequency Range	50HZ / 60HZ						
Lithium battery capacity	1036Wh	1554Wh	2072Wh	2590Wh	3108Wh	3885Wh	5200Wh
Battery voltage	25.9V~29.4V (options ) (25.6~29.6V)						
Life Span	1500 Cycles to 80%+ capacity						
Management Systems	BMS with Over Voltage Protection Overload Protection;Over Temperature Protection Short Circuit Protection;Low Temperature Protection Low Voltage Protection;Overcurrent Protection						
Solar charge	20A (26-50V 720w)		30A (26-50V 1100w)		60A (26-50V 2160w)		
Adapter charging	AC 220V/110V~29.4V5A (Additional custom is required for higher current )						
DC charge	DC Adapter 29.4V5A						
Cigarette lighter output	12V10A max 120w						
DC output	2 * 12V8A max						
USB QC 3.0 output	4PCS 5V/3A, 9V/2A, 12V/1.5A						
Type-C Bothway	Charge by USB-C PD 65W ; Output PD 65W, 5V/3A, 9V/3A, 12V/3A, 15V/3A, 20V/3.25A						
Type-C output	PD 45W, 5V/3A, 9V/3A, 12V/3A, 15V/3A						
Wireless charging	2 * 5V10W						
LED Lighting lamp	SAL series (2*3W , Built-in LED lights with more power require additional customization )						
Music player	SALM series (FM radio / Bluetooth、3W~5W trumpet , need to choose a higher configuration model )						
Speech control	SALM series (Switch on and off with voice control of various functions , need to choose a higher configuration model )						
Multimachine parallel	SALM series ( need to choose a higher configuration model )						
UPS	SAU series ( need to choose a higher configuration model )						
network communications	SAA series ( need to choose a higher configuration model )						
Storage temperature	-10℃ ~ +45℃						
working temperature	-10℃ ~ +65℃						
Warranty	12 months						
Testing and certification	UL / CE / FCC / RoHS / PSE / KC						
L*W*H ( mm )	384*249*290		384*249*330		384*249*350		384*249*450
Weight ( KG )	14.6	18.2	21	23.2	27.3	30.2	38.1

## FAQs

The S series is a versatile tool on many adventures, so that simple cleaning will likely be required from time to time.

### How do I clean for S series?

Use dry, non-abrasive cloths to wipe. If you need to clean more thoroughly, we recommend that you use detergent that used for cleaning mobile phones and computer screens. Do Not expose S series to lots of liquid.

### How do I store S series?

Please store S series in a dry and cool place. DO NOT place it near water. If you need to store S series for a long time, please charge the battery to around 85%, in order to extend battery life. Then turn off the main switch and store at room temperature. Charging once every 2 months .

### How do I use S series safely?

Please use S series in its operating temperature range. Using S series out of the optimal operating temperature range may cause S series to exceed its safe and effective working limits. DO NOT immerse S series in water. Doing so will void the warranty. S series is not waterproofed.

## What's in the Box

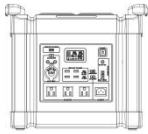

S series



DC adapter



User Manual and warranty card.

NO.	PRODUCT	Quantity (pcs)
1	S series	1
2	Charging Adapter	1
3	User Manual	1
4	Warranty Card	1